

About this Manual

We've added this manual to the Agilent website in an effort to help you support your product. This manual is the best copy we could find; it may be incomplete or contain dated information. If we find a more recent copy in the future, we will add it to the Agilent website.

Support for Your Product

Agilent no longer sells or supports this product. Our service centers may be able to perform calibration if no repair parts are needed, but no other support from Agilent is available. You will find any other available product information on the Agilent Test & Measurement website, www.tm.agilent.com.

HP References in this Manual

This manual may contain references to HP or Hewlett-Packard. Please note that Hewlett-Packard's former test and measurement, semiconductor products and chemical analysis businesses are now part of Agilent Technologies. We have made no changes to this manual copy. In other documentation, to reduce potential confusion, the only change to product numbers and names has been in the company name prefix: where a product number/name was HP XXXX the current name/number is now Agilent XXXX. For example, model number HP8648A is now model number Agilent 8648A.

User Manual

**HP E7580A
ProBER 2**

© Copyright Hewlett-Packard
Ltd.1998

All rights reserved.
Reproduction, adaption, or
translation without prior written
permission is prohibited,
except as allowed under the
copyright laws.

HP Part No. E7580-90000

First edition, 12/98

Printed in U.K.

Warranty

The information contained in
this document is subject to
change without notice.

*Hewlett-Packard makes no
warranty of any kind with
regard to this material,
including, but not limited to, the
implied warranties or
merchanability and fitness for a
particular purpose.*

Hewlett-Packard shall not be
liable for errors contained
herein or for incidental or
consequential damages in
connection with the furnishing,
performance, or use of this
material.

WARNING

For details of safety, see Safety
information at the front of this
manual.

Warning Symbols Used on the Product



The product is marked with this
symbol when the user should
refer to the instruction manual
in order to protect the apparatus
against damage.

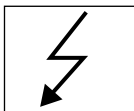

The product is marked with this
symbol to indicate that
hazardous voltages are present

Hewlett-Packard Limited
Telecommunications Networks Test Division
South Queensferry
West Lothian, Scotland EH30 9TG

User Manual

Serial Numbers

This manual applies directly to instruments with serial numbers GB00000101 and above.

HP Part Number E7580A-90000

Printed in U.K. December 1998

HP E7580A
ProBER 2

Contents

Managing the Displays 1

- Accessing the Displays 2
- Navigating the Displays 3
- Modifying Display Data. 5

Setting the Interfaces 7

- Connecting to the Network 8
- Setting Transmit & Receive Interfaces 9
- AutoSetup 11

Test Setup Features 13

- Adding Errors & Alarms 14
- Adding Frequency Offset 15
- Setting Signalling Bits 17
- Setting Spare Bits 18
- Setting Framing Bits 19
- Generating a VF Tone 20
- Configuring as a Telephone Handset 22
- Enabling DTMF Dialling 23

Making Measurements 25

- Setting Test Timing 26
- Measuring Errors & Alarms 28
- Measuring Error Analysis 30
- Performing a Trouble Scan 32
- Measuring Round Trip Delay 34
- Measuring Frequency 36
- Making Pulse Mask Measurement 37
- Measuring Signal Level 39
- Measuring Jitter 40
- Measuring a VF Tone (Using Channel Map) 42
- Monitoring Signalling Bits 44
- Monitoring Spare Bits 45
- Monitoring Framing Bits 46

Graphs & Logging 47

- Saving Graph Results 48
- Recalling Graph Results 49
- Viewing Graph Results 50

Contents

- Logging Results 52
- Connecting an HP 15730A Printer 54
- Printing a Display 55

Using Other Features 57

- Setting Time & Date 58
- Storing & Titling Instrument Settings 59
- Recalling Instrument Settings 60
- Setting Beep on Error/Alarm 61
- Setting Backlight Mode 62
- Setting Display Contrast 63
- Choosing Local Language Help Messages 64
- Charging the Battery 65
- Running Self Test 68

Accessing the Displays

Navigating the Displays

Modifying Display Data

Managing the Displays

Accessing the Displays

The operator interface is provided by the display softkeys and the front panel keys.

The display softkeys provide access to seven different display areas.:

TX/RX Setup

Allows control of the main Transmit and Receive settings.

Test Setup

Allows control of the test features: Errors & Alarms, Frequency Offset, Channel Associated Signalling Setup, VF Tone Transmission, DTMF Dialling, Frame Control and Spare Bit Setup.

Results

Allows control of the Test timing and displays the selected measurement results.

Signal Quality

Allows control of Jitter measurements and displays received frequency offset, level, pulse mask and jitter results.

Graphs

Displays the stored graphical results.

Log/Print

Allows control of logging results to the external printer.

Other

Allows control of Time & Date, Talk/Listen, Calibration, Self Test, Instrument Settings, Beep on Error, Beep on Alarm, Backlight Mode, Display Contrast, Language and Battery Life. A list of the Options fitted is also displayed.

To move within the display areas use ▼ ▲ ◀ and ▶. To return quickly to the top of the display, press **MENU**.

Navigating the Displays

- 1 In each of the display areas the field currently able to be changed is marked by a "highlighted cursor".

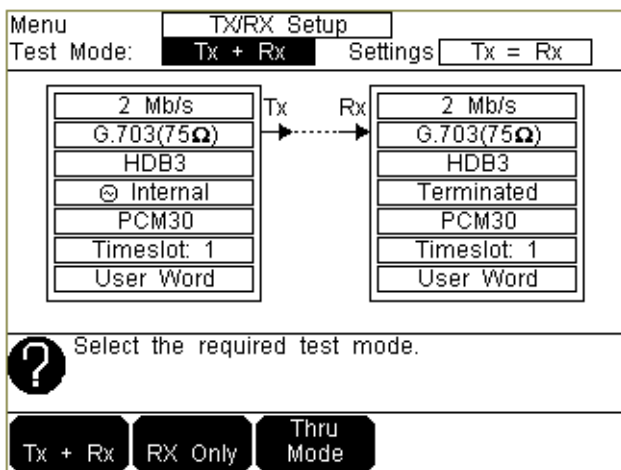

- 2 The menu of selections available, for the active field, are displayed on softkeys at the bottom of the display. The choice from the menu is made using the keys situated immediately below the display
- 3 The "highlighted cursor" is moved around the display using ▼ ▲ ◀ and ▶ or can be quickly returned to the top of the display by pressing **MENU**.

Menu TX/RX Setup

Test Mode: Tx + Rx Settings Tx = Rx

2 Mb/s	Tx	Rx	2 Mb/s
G.703(75Ω)	→		G.703(75Ω)
HDB3			HDB3
⊙ Internal			Terminated
PCM30			PCM30
Timeslot: 1			Timeslot: 1
PRBS15 ITU			PRBS15 ITU

? Select the required test pattern.

Dial/
VF Tone PRBS9 PRBS11 PRBS15 MORE

- 4 When a field has more than five choices a softkey labelled **MORE** is provided. When **MORE** is chosen the remainder of the menu is revealed.

Modifying Display Data.

Display data is modified using ▼ ▲ ◀ ▶, the display softkeys, **ENTER** and **Cancel**.

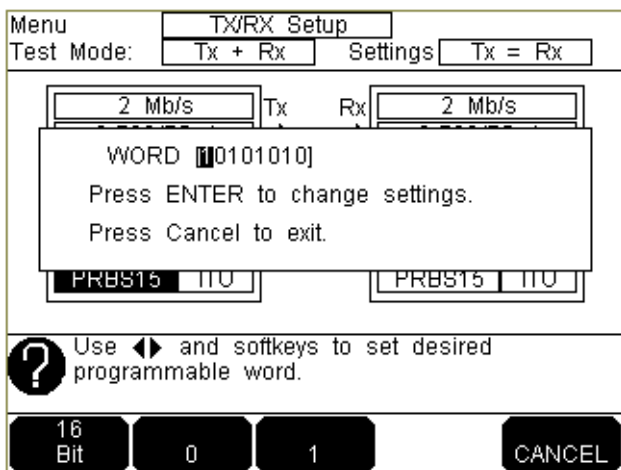

- 1 In the USER WORD example ◀ and ▶ move the cursor to the bit to be edited.

8 Bit and **16 Bit** allows you to change the Word length.

0 and **1** change the value of the chosen bit.

ENTER actions the changes and exits the edit.

Cancel allows you to exit the edit without change.

Setting the Interfaces

Connecting to the Network

TX & RX Interfaces

Autosetup

Setting the Interfaces

Connecting to the Network

HP ProBER 2 provides 75 Ω unbalanced and 120 Ω balanced transmit and receive interfaces.

NOTE

To prevent distortion of the results only connect cables to one of the Transmit or Receive ports i.e. 75 Ω or 120 Ω

The receive interface termination can be:

Terminated - 0dB Gain

Monitor 20dB Gain - to compensate for a low level signal at a network equipment monitor point.

Monitor 26dB Gain - to compensate for a low level signal at a network equipment monitor point.

Monitor 30dB Gain - to compensate for a low level signal at a network equipment monitor point.

Bridged - high impedance.

HP ProBER 2 also provides a 75 Ω EXT CLOCK IN port which accepts a 2 MHz clock source complying with ITU-T G.703 Section 10 (Reference 1).

Setting Transmit & Receive Interfaces

Description:

HP ProBER 2 can be configured to:

Transmit and Receive simultaneously,

Operate in Receive Only mode or

Operate in Thru Mode.

Thru Mode allows non-intrusive monitoring of live traffic.

NOTE

Receive Only mode extends the time between battery charges.









Access Display:

Choose **MENU** **TX/RX Setup** to obtain the Transmit & Receive interface display.

HOW TO:

- 1 Make your choice of operating mode. If **Tx + Rx** is chosen the Transmit and Receive settings can be coupled together or independent of each other:
 - Tx = Rx** - any change made on either TX or RX will automatically occur on the other
 - Tx ≠ Rx** - changes to TX and RX settings must be made independently of each other.If **Rx Only** is chosen only the Receive settings are available.
If **Thru Mode** is chosen the received signal can be:
 - Transparent** - returned to the network without being modified.
 - Overwrite** - modified before return to the network

Setting the Interfaces

- 2 Choose the Line Rate required.
If Option 002, Co-directional Interface, is fitted **64 kb/s** is added to the menu.
- 3 Choose the Line Impedance required. If Line Rate **64 kb/s** (Option 002 only) is chosen only **G703 (120Ω)** is available.
- 4 Choose the Clock Source required. If **External** is chosen a 2 MHz clock complying with ITU-T G.703 Section 10 (Reference 1) must be connected to the 75Ω EXT CLOCK IN port.
- 5 If Line Rate **64 kb/s** is chosen choose the OCTET state.
- 6 If Line Rate **2 Mb/s** is chosen, choose the 2 Mb/s Frame Type.
- 7 If any Frame Type other than **Unframed** is chosen choose the test Timeslots.
Use  and  to select a single timeslot or use **Edit**    , and **Select/Delete**, **Select/Delete All**  and  to select single or multiple timeslots.
Press **ENTER** to action your edits. Press **Cancel** to escape.
- 8 Choose a test PRBS/Word Pattern or a test VF Tone. The TX and RX test patterns are coupled. A change on one will occur on the other except when **Live** is chosen as the Receive pattern.
If **Live** is chosen as the Receive pattern then bit error measurements are disabled.
If **User Word** is chosen use **User Word** **8 BIT**, **16 BIT**, **0** and **1** to set the user word value.
Press **ENTER** to action your edits. Press **Cancel** to escape.
If **Dial/VF Tone** is chosen see, “Generating a VF Tone” on page 20

AutoSetup

Description:

HP ProBER 2 can be configured to match the received signal using the **AUTOSETUP** feature.

When **AUTOSETUP** is pressed HP ProBER 2 will monitor the received signal to detect the line rate. If 64 kb/s or 2.048 Mb/s is not detected Autosetup will halt and Signal Loss will be indicated.

If 64 kb/s or 2.048 Mb/s is detected HP ProBER 2 will attempt to match the framing present on the received signal. If PCM30, PCM31, PCM30CRC or PCM31CRC is not detected it will be assumed the received signal is Unframed.

HP ProBER will next check for a valid test pattern in the received signal.

If a valid test pattern is not detected the Line Rate and Framing settings will be retained.

NOTE

1. If a measurement is running under the control of Test Timing, this must be halted by pressing **START/STOP** before Autosetup can be used.
 2. If Autosetup is running and you wish to make a measurement under the control of Test Timing, Autosetup must be halted by pressing **AUTOSETUP**.
-

Setting the Interfaces

Test Setup Features

Add Errors/Alarms

Add Frequency Offset

Set CAS Signalling Bits

Set Spare Bits

Set Framing Bits

Generate a VF Tone

Use HP ProBER as a Telephone Handset

Test Setup Features

Adding Errors & Alarms

Description:

Errors and alarms can be added to the transmit signal during testing. An indication of received alarms and errors is displayed.

The following alarms and errors can be added:

- **Alarms** - Loss of signal, AIS, Loss of frame, Timeslot AIS, RDI, RDI MF.
- **Errors** - Bit, Code, FAS, CRC, E-bit.

Bit, Code, CRC and E-bit errors can be added singly or at one of the predetermined error rates in the range $1 \times E^{-3}$ to $1 \times E^{-7}$. FAS errors can be added at 1 in 4, 2 in 4, 3 in 4 and 4 in 4 (all).

NOTE

If option 001, Advanced Signal quality Measurements, is fitted and Jitter is enabled Error Add is disabled but Alarm add is available.

Access Display:

Choose **MENU** **Test Setup** **Alarm/Error** to obtain the Error & Alarm Add display.

HOW TO:

- 1 Choose the **Alarm Type**.
- 2 Choose the **Error Add Type** and **Rate** required. Errors and Alarms can be added to the transmit signal at the same time.

Adding Frequency Offset

Description:

The capability of the network equipment to reliably recover the clock is tested by varying the clock rate of the generated data and checking for the occurrence of errors.

The measurement can be made in a loopback or a cross multiplexer configuration, and is generally of short duration.

Frequency Offset can only be added to the generated 2 Mb/s signal if Clock Source **Internal** is chosen.

Frequency Offset can be added at:

- Preset ITU values - **+50ppm** and **-50ppm**
- User defined values in the range ± 100 ppm.

The frequency of the received signal and the frequency offset present on the received signal are displayed on the **MENU** **Test Setup** **Freq Offset** display.

NOTE

The Frequency of the received signal and the Frequency offset present on the received signal is also displayed on the **MENU** **Signal Quality** **Freq** display.

Access Display:

Choose Clock Source **Internal** on the **TX/RX Setup** display and press **MENU** **Test Setup** **Freq Offset** to prepare to add Frequency offset.

HOW TO:

- 1 Choose the amount of Frequency offset required from the menu.

If you wish to add frequency offset at other than the preset values, use **Edit**, ◀, ▶, ▼ and ▲ to choose the amount of frequency offset.

Press **ENTER** to action your edits. Press **Cancel** to escape.

Setting Signalling Bits

Description:

Channel Associated Signalling (CAS) is transmitted in Timeslot 16 when **PCM30** or **PCM30CRC** framing is chosen on the **TX/RX Setup** display. CAS provides the information necessary for switching and routing all 30 timeslots.

The ability to set the value of the CAS bits allows testing of the routing and switching of any or all of the timeslots.

Access Display:

Choose **MENU** **Test Setup** **CAS** to obtain the Channel Associated Signalling setup display.

HOW TO:

- 1 Use **▼ ▲ ◀ ▶**, **0** and **1** to set the value of the CAS signalling bits.

Setting Spare Bits

Description:

With **PCM30CRC** or **PCM31CRC** framing, spare bits Sa4 to Sa8 can be used to send optional network messages, for example a Synchronization Status Message.

Access Display:

Choose **MENU** **Test Setup** **Sa Bit Control** to obtain the Spare Bit setup display.

HOW TO:

Synchronization Status Message

- 1 Choose the Sa bit in which the Sync Message is to be inserted.
Choose the Sync Message to be inserted.

Bit Value

- 2 Use **▼ ▲ ◀ ▶**, **0** and **1** to set the spare bit value.

Setting Framing Bits

Description:

When **PCM30** or **PCM30CRC** framing is chosen the Multiframe Alignment Signal (MFAS) provides synchronization of the signalling multiframe.

When **PCM30CRC** or **PCM31CRC** framing is chosen a CRC-4 Multiframe is formed. CRC MFAS provides synchronization of the CRC-4 Multiframe.

On the **Frame Control** display the following frame bits can be set:

- **PCM30** - Si-bits, Sa4 - Sa8, MFAS, X-bits
- **PCM30CRC** - MFAS, X-bits, CRC MFAS
- **PCM31** - Si-bits, Sa4 - Sa8
- **PCM31CRC** - CRC MFAS

Access Display:

Choose **MENU** **Test Setup** **Frame Control** to obtain the Frame Control display.

HOW TO:

- 1 Use **▼ ▲ ◀ ▶**, **0** and **1** to set the required bit values.

Generating a VF Tone

Description:

Telephone channels can be verified by insertion of a Voice Frequency Tone at the transmitter. The tone should be variable in level and frequency.











NOTE

The frequency and level of the received tone is displayed.











Access Display:

Choose **Dial/VF Tone** under Test Pattern on the **TX/RX Setup** display and choose **MENU** **Test Setup** **VF Tone** to obtain the VF Tone test display.

HOW TO:

- 1 Choose the timeslot in which you wish to insert the VF Tone.
Use  and  to select a single timeslot or use **Edit**    , **Select/Delete** and **Select/Delete All** to select a single or multiple timeslots.
Press **ENTER** to action your edits. Press **Cancel** to escape.
- 2 If required, choose **Dial** to enter a phone number for dialling.
Use    , **INS** and **DEL** to enter the phone number.
Press **ENTER** to dial the number. Press **Cancel** to escape.

Test Setup Features

- 3 Choose a preset tone frequency or make your own choice using **Edit**,    and . Press **ENTER** to action your edits. Press **Cancel** to escape.
- 4 Use **Edit**,    and  to choose the tone level. Press **ENTER** to action your edits. Press **Cancel** to escape.
- 5 Adjust the loudspeaker volume if required using  and .

Configuring as a Telephone Handset

Description:

You can use HP ProBER 2 as a telephone handset by talking into the built-in microphone and listening to the built-in loudspeaker.







It can be connected to a 64 kb/s voice channel (Timeslot) for communication purposes.

Access Display:

Choose **MENU** **Other** **Talk/Listen** to obtain the Talk/Listen display.

HOW TO:

- 1 Choose the timeslot (voice channel) in which you wish to communicate.



Use  and  to select a single timeslot or use **Edit**  , and **Select/Delete**  .

Select All , **Clear All** to select single or multiple timeslots.

Press **ENTER** to action your edits. Press **Cancel** to escape.

- 2 If required choose **DTMF Dialling** to enter a phone number for dialling.

Use **INS** and **DEL** to set the number of digits in the phone number.

Use    , **INS** and **DEL** to enter the phone number.

Press **ENTER** to dial the number. Press **Cancel** to escape.

- 3 Adjust the loudspeaker volume as required using  and .

Enabling DTMF Dialling

Description:

DTMF Dialling allows dialling of phone numbers to establish a communications or test channel.

Access Display:

Via Talk/Listen

Choose **MENU** **Other** **Talk/Listen** move the cursor to **Talk** and choose **DTMF Dialling** to obtain the DTMF Dialling display.

Via VF Tone

Choose **MENU** **Test Setup** **VF Tone** move the cursor to **Dial** and choose **Dial** to obtain the DTMF Dialling display.

HOW TO:

- 1 Enter the number to be dialled using **◀ ▶ ▼ ▲**, **INS** and **DEL** to insert the phone number. Press **ENTER** to dial the number. Press **Cancel** to escape.
The status message *“Dialling DTMF Number Now”* is displayed in the Help window during dialling.

Test Setup Features

Making Measurements

Set Test Timing

Errors & Alarms

Error Analysis

Trouble Scan

Delay

Frequency

Pulse Mask

Signal Level

Jitter

VF Tone

Signalling Bits

Spare Bits

Framing Bits

Making Measurements

Setting Test Timing

Description:

The test measurement period may be:

- **Manual** - Started and stopped by pressing **START/STOP**.
- **Single** - Set to a predetermined duration. Started by **START/STOP** and stopped automatically at the end of the timed period.
- **Delayed** - Set to a predetermined duration. Started automatically at the programmed date and Time and stopped automatically at the end of the timed period.

The test duration can be a preset period of 10 seconds, 1 minute, 15 minutes, 1 hour or a user defined period up to 99 days, 23 hours, 59 minutes, 59 seconds.

NOTE

Test durations greater than 8 hours are only possible if HP ProBER 2 is connected to the line supply via the DC charger.

While the measurement is running the elapsed test time is displayed at the bottom right of the **Results** display.

Access Display:

Choose **MENU** **Results** **Test Timing** to obtain the Test Timing display.

HOW TO:

- 1 Select the type of **Test Timing** you require.
- 2 If **Manual** is chosen the test must be Started and stopped by pressing **START/STOP**.
- 3 If **Single** is chosen move the cursor to **Duration** and choose a preset measurement period or your own measurement period.
To choose your own measurement period use **User**, **◀ ▶ ▼ ▲**.
Press **ENTER** to action your edits. Press **Cancel** to escape.
Press **START/STOP** to Start the test.
- 4 If **Delayed** is chosen move the cursor to **Duration** and choose a preset measurement period or choose you own measurement period.
To choose your own measurement period use **User**, **◀ ▶ ▼ ▲**.
Press **ENTER** to action your edits. Press **Cancel** to escape.
- 5 Move the cursor to **Start** and set the start date using **Edit**, **◀ ▶ ▼ ▲**.
Press **ENTER** to action your edits. Press **Cancel** to escape.
- 6 Move the cursor to **Time** and enter the start time using **Edit**, **◀ ▶ ▼ ▲**.
Press **ENTER** to action your edits. Press **Cancel** to escape.
The test will start when the start date and start time are reached.

Measuring Errors & Alarms

Description:

Error Count, Error Ratio and Errored Second Results are available for each of the following Error sources:

- Bit
- Code
- FAS
- CRC
- E-Bit

A Summary of the results is available and provides an Error Count, Error Ratio and Errored Seconds for each of the error sources listed above and in addition an Alarm Seconds Count.

The following Alarm Seconds Results are available:

- LOS (Loss of Signal)
- AIS
- LOF (Loss of Frame)
- TS AIS (Timeslot AIS)
- CAS MF Loss (CAS Multiframe Loss)
- Pattern Loss
- RDI (Remote Defect Indication)
- RDI MF (Multiframe Remote Defect Indication)

Access Display:

Choose **MENU** **Results** **Errors+Alarms** to obtain the Error and Alarm Results display.

HOW TO:

- 1** Set up the transmit and receive interfaces. See, “Setting Transmit & Receive Interfaces” on page 9.
- 2** Choose the Test Timing required and start the test by pressing **START/STOP**. See, “Setting Test Timing” on page 26.
- 3** Choose the error summary, individual error results (Bit, Code, FAS, CRC or E-bit) or alarm seconds results for viewing. Any of the other results can be viewed without affecting the measurement.

Measuring Error Analysis

Description:

Analysis Results conforming to G.821 and G.826 are provided.

G.821 - Count and ratio Results of Errored Seconds, Error Free Seconds, Severely Errored Seconds, Degraded Minutes and Unavailable Seconds are displayed for the following error sources:

- Bit
- FAS
- CRC
- E-Bit

In addition, an Annex D Errored Seconds ratio, a Code Error Seconds count and a Pass/Fail result are displayed.

G.826 - In service, Near End and Far End Results of Errored Blocks, Background Block Error, Errored Seconds, Severely Errored Seconds, Unavailable Seconds and a Pass/Fail result are displayed.

In addition, Out of Service results of Errored Blocks, Background Block Error, Errored Seconds, Severely Errored Seconds, Unavailable Seconds and a Pass/Fail result are displayed.

Path Allocation

The Pass/Fail result is based on preset threshold settings. If a threshold is exceeded a FAIL result is displayed.

Making Measurements

When measuring over a part of a path the Pass /Fail thresholds need to be reduced according to the percentage of the path being measured.

The path allocation percentage reduces the threshold on a pro-rata basis.

The following Pass/Fail thresholds apply to a path allocation of 100%:

- G.821 - ESR <0.08, SESR < 0.002
- G.826 - ESR <0.04, SESR <0.002, BBER 2×10^{-4}

G.826 Analysis allows the setting of a Path Unavailable Seconds (PUAS) threshold. If the threshold is set and a PUAS count in excess of the threshold is measured a FAIL result is displayed.

The PUAS threshold is unaffected by the Path Allocation.

Access Display:

Choose **MENU** **Results** **Analysis** **G.821** or **G.826** to obtain the Analysis Results menu.

HOW TO:

- 1 Set up the transmit and receive interfaces. See, "Setting Transmit & Receive Interfaces" on page 9.
- 2 Choose the Test Timing required and start the test by pressing **START/STOP**. See, "Setting Test Timing" on page 26.
- 3 Choose G.821 or G.826 analysis results for viewing.
Any of the other results can be viewed without affecting the measurement.

Performing a Trouble Scan

Description:

Problems in the network at all levels of the hierarchy can be detected by the occurrence of errors and alarms.

When performing a Trouble Scan all possible error sources and alarms are scanned simultaneously. Any error count which is other than zero is displayed.

Up to four non-zero error counts are displayed in priority order:

- CRC
- E BIT
- CODE
- FAS
- BIT
- Jitter Hits (Option 001 only)

If any alarms are active an Alarm Seconds count is displayed.

Access Display:

Choose **MENU** **Results** **Trouble Scan** to obtain the Trouble Scan display.

HOW TO:

- 1 Set up the receive interface and if necessary the transmit interface. See, "Setting Transmit & Receive Interfaces" on page 9.

Making Measurements

- 2 Choose the Test Timing required and start the test by pressing **START/STOP**. See, “Setting Test Timing” on page 26.

Measuring Round Trip Delay

Description:

The time taken for voice or data traffic to pass through the network is very important as excessive delay adds distortion. Speech is particularly affected by delays longer than 150 ms.

Round Trip Delay - is a measurement of the total delay on the 'go' and 'return' legs of a duplex path and is typically in the order of milliseconds.

HP ProBER 2 measures the time taken for a test pattern to be transmitted over the 'go' and 'return' legs of a duplex network path.

A test pattern is transmitted in a N X 64 kb/s path (or 2 Mb/s unframed path) and a timer is set running. A loopback is manually applied to the network equipment to return the test signal.

The received pattern stops the timer and the round trip delay is calculated.

NOTE

1. Round trip delay is only possible at 2 Mb/s Line Rate.
 2. Any error measurement must be stopped before the delay measurement can be made.
 3. The delay measurement must be terminated before an error measurement can be started.
-

Making Measurements

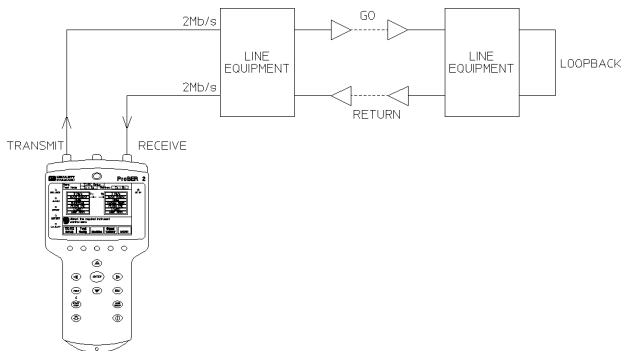

HOW TO:

- 1 If an error measurement is running press **START/STOP** to terminate the measurement.
- 2 Set up the transmit and receive interfaces. See, “Setting Transmit & Receive Interfaces” on page 9.
- 3 Connect a loopback to the network equipment.
- 4 Choose **MENU Results Delay** to view the delay results.
- 5 Choose **Delay Test ON** to start the measurement.
The delay measurement range is up to 2 seconds with a resolution of 1 microsecond.

Measuring Frequency

Description:

HP ProBER 2 measures the frequency of a received 2 Mb/s signal relative to the internal reference clock.

The frequency offset is also measured within the limits specified in ITU-T G.703 $< \pm 50$ ppm.

NOTE

Frequency measurement is not available when a Line Rate of 64 kb/s is chosen.

Access Display:

Choose **MENU** **Signal Quality** **Freq** to obtain the Frequency display.

HOW TO:

- 1 Set up the receive interface. See, "Setting Transmit & Receive Interfaces" on page 9.

Making Pulse Mask Measurement

Description:

The received pulse is superimposed on the ITU-T G.703 mask and a comparison is made. A **Pulse Mask: Pass** or **Fail** result is displayed.

The comparison can be made on positive pulses or negative pulses. Alternatively the Pulse Mask can be turned off and no comparison made.

Pulse width ratio and the pulse amplitude ratio results are also displayed. The ratios are calculated from positive with respect to negative.

NOTE

1. Pulse Mask measurement is only possible when Option 001, Advanced Signal Quality Measurements, is fitted.

2. Pulse Mask measurement is not available when a Line Rate of 64 kb/s is chosen.

Access Display:

Choose **MENU** **Signal Quality** **Pulse Mask** to obtain the Pulse Mask display and start the pulse capture.

HOW TO:

- 1 Set up the receive interface. See, "Setting Transmit & Receive Interfaces" on page 9.

Making Measurements

- 2 Choose **MENU** **Signal Quality** **Pulse Mask**, then press **START/STOP**.
This will start the pulse capture.
Status message "*Pulse capture in progress*" indicates that the measurement has started.
- 3 When the pulse is displayed, enable or disable the ITU-T G.703 Mask and choose the captured pulse polarity.

Measuring Signal Level

Description:

NOTE

1. Signal Level measurement is only possible when Option 001, Advanced Signal Quality Measurements, is fitted.
2. Signal Level measurement is not available when a Line Rate of 64 kb/s is chosen.

Access Display:

Choose **MENU** **Signal Quality** **Level** to obtain the Level Results.

HOW TO:

- 1 Set up the receive interface, See, "Setting Transmit & Receive Interfaces" on page 9.

Measuring Jitter

Description:

Simultaneous Jitter and Error measurements are made when a jitter option is fitted and the jitter measurement is enabled.

Jitter Amplitude and Jitter Hits results are provided:

- **Amplitude** - Peak to Peak, Positive Peak, Negative Peak
- **Hits** - Hit count, Hit seconds, Hit free seconds

A selection of jitter filters is provided to allow received jitter to be compared with the maximum input tolerance of the ITU-T G.823 and G.783 masks:

- HP1 - 20 Hz high pass
- HP2 - 18 kHz high pass
- LP 100 kHz low pass

Filters **OFF** allows jitter measurement in the range 2 Hz to greater than 100 kHz on the 1.6 UI range.

The 16 UI range is particularly useful in identifying jitter originating from pointer movements.

NOTE

1. Jitter measurement is only possible when Option 001, Advanced Signal Quality Measurements, is fitted.

2. Jitter measurement is not available when a Line Rate of 64 kb/s is chosen.

3. When Jitter measurement is enabled the Error Add feature is not available.

Access Display:

Choose **MENU** **Signal Quality** **Jitter** to configure the jitter receiver and view the jitter Results.

HOW TO:

- 1 Set up the receive interface and transmit interface if necessary, See, “Setting Transmit & Receive Interfaces” on page 9.
 - 2 Enable the jitter measurement by choosing **ON**.
 - 3 Choose the jitter measurement range required from the menu (1.6 UI or 16 UI).
 - 4 Move the cursor to **Hit Threshold** and using **Edit** **◀ ▶ ▼ ▲** choose the hit threshold value. Press **ENTER** to action your edits. Press **Cancel** to escape.
 - 5 Choose the jitter measurement filter required from the menu.
 - 6 Choose the Test Timing required and start the test by pressing **START/STOP**. See, “Setting Test Timing” on page 26.
 - 7 Any of the other results can be viewed without affecting the measurement.
-

Measuring a VF Tone (Using Channel Map)

HP ProBER 2 measures the frequency and level of a voice frequency tone in a selected timeslot.

The measured VF tone frequency and level is available on the **Results Channel Map** display.

Channel Map allows you to scan all the received timeslots. Any timeslot which has activity is highlighted. (indicated by black shading)

The display softkeys can be used to jump between "active" timeslots.

The loudspeaker volume can be adjusted to give an audible indication of timeslot activity.

The frequency and level of the tone, in the chosen timeslot, are displayed.

NOTE

1. When generating a VF tone the frequency and level of the received VF tone also appear on the **Test Setup VF Tone** display.
2. VF Tone measurement is not available when error measurements are running or a Line Rate of 64 kb/s is chosen.







Access Display:

Choose **MENU Results Channel Map** to obtain the Channel Map display.



HOW TO:

- 1 Set up the receive interface and if necessary the transmit interface. See, "Setting Transmit & Receive Interfaces" on page 9.

- 2 Move the cursor to Timeslot and choose the timeslot to monitor.

 and  move the pointer to first /last timeslot.  and  move the pointer from the "active" timeslot to next/previous "active" timeslot.  and  move the pointer to the adjacent timeslot.

The level and frequency of the tone is displayed at the bottom of the display.

- 3 If required adjust the loudspeaker volume level using  and .

Monitoring Signalling Bits

Access Display:

Choose **MENU** **Results** **CAS Monitor** to obtain the CAS Monitor display

Monitoring Spare Bits

HP ProBER 2 displays the Synchronization Status Message in the chosen Sa Bit and the value of all the Sa Bits.

Access Display:

Choose **MENU** **Results** **Sa Bit Monitor** to obtain the Spare Bits monitor display.

HOW TO:

- 1 Choose the Sa Bit to be monitored for Synchronization Status Messages. Each Sa Bit can be chosen in turn without affecting the measurement.

Monitoring Framing Bits

Access Display:

Choose **MENU** **Results** **Frame Monitor** to obtain the Frame Monitor display.

Graphs & Logging

Saving Graph Results

Recalling Graph Results

Viewing Graph Results

Logging Results

Connecting a Printer

Printing a Display

Graphs & Logging

Saving Graph Results

Description:

HP ProBER 2 provides graphical representation of measurement results:

- Correlation of error, jitter and alarm results
- Display of error, jitter and alarm results versus time
- Overview of the results which can be stored in the instrument for record keeping.

Up to 10 sets of measurement results can be stored in HP ProBER 2.

Access Display:

Choose **MENU** **Graphs** to obtain the graph results.

HOW TO:

- 1 Move the cursor to Store and choose **Select Store**.
- 2 Use **▼** and **▲** to access the instrument store in which you wish to store the graph results.
- 3 Choose **Save** to confirm the saving of the graph results obtained from the "last" measurement. Choose **Cancel** to exit without saving the graph results. Choose **ENTER** to view the graph results from the selected store. Choose **Delete** to clear the contents of the selected store.

Recalling Graph Results

Description:

Results stored from a previous measurement can be recalled to the graphics displays for viewing.

Access Display:

Choose **MENU** **Graphs** to obtain the graph display.

HOW TO:

- 1 Move the cursor to **Store** and choose **Select Store**.
- 2 Use **▼** and **▲** to access the instrument store which contains the graph results you wish to recall.
- 3 Choose **ENTER** to recall the graph results from the selected store to the display.
Choose **Cancel** to exit without recalling the graph results.
Choose **Delete** to clear the contents of the selected store.

Viewing Graph Results

Description:

All the graphic results obtained during the measurement are available for viewing.

Results are recorded with a resolution of 1 second. **Zoom In** and **Zoom Out** allow you to dynamically change the resolution used to display the graph results. Resolutions of 1 second, 1 minute, 15 minutes and 1 hour are available.

You can move the cursor to a particular area of interest using ◀ and ▶. The cursor position is displayed at the top right of the display as a time and date.

The graph results can also be viewed in text format as cumulative results.

The error count graphs give text results of Error Count, Error Ratio, Error Seconds.

The Alarm graphs give text results of Alarm Seconds.

Access Display:

Choose **MENU** **Graphs** **Last** to obtain a graphical display of the most recent set of measurement results.

HOW TO:

- 1 Use ▼ and ▲ to move between the upper and lower graphs.
- 2 Use **Next** and **Previous** to scroll through the graph results.

Graphs & Logging

- 3 Use ◀ and ▶ to move the graph cursor to the area of interest.
- 4 Use **Zoom In** and **Zoom Out** to allow more detailed inspection of the graph results by reducing/increasing the time axis.
- 5 Press **Text** to view text results. Press **Graph** to return to graph results.

Logging Results

Description:

Test Period Logging

If degradations in system performance can be observed at an early stage, then the appropriate remedial action can be taken to maximize circuit availability and avoid system crashes. Test period logging allows you to monitor the error performance of your circuit. At the end of the test period the selected results are logged.

Results can be logged at regular intervals during the test period by selecting a **Logging Interval** of shorter duration than the test period.

Error Event Logging

Manual tracing of intermittent faults is time consuming. Error event logging allows you to carry out unattended long term monitoring of the circuit. Each occurrence of the Selected error event is logged.

Any Alarm occurrence results in a timed and dated message being logged.

Access Display:

Choose **MENU** **Log/Print** to obtain the Logging display.

HOW TO:

- 1 Choose **Filters** and choose the results to be Logged.
 - Interval Results** - Log results obtained during the Logging Interval.
 - Total Results** - Log cumulative results obtained since the start of the measurement.
 - Error Counts** - Log all valid error counts (Bit, Code, FAS, CRC, E-bit).
 - Alarm Seconds** - Log Alarm Seconds
 - G.821** - Log chosen G.821 results (All, Bit, FAS, CRC, E-Bit).
 - G.826** - Log chosen G.826 results (All, In-Service, Out of Service).
 - Frequency** - Log the received frequency.
 - Signal Level** - Log the received signal level.

Each or all of these Filters can be switched **OFF**.

- 2 Choose **Setup** and choose the logging Setup.
 - Logging Mode** - Enables logging.
 - Log Errored Secs.** - Provides a timed and dated message each time an error or alarm occurs.
 - Logging Interval** - Choose the interval for logging results to the printer. If **User** is chosen use ◀ ▶ ▼ and ▲ to choose the logging interval.
 - Log When** - Log always or only when error count is greater than zero.
 - Printer Type** - Choose HP or alternative supplier's printer according to type of printer connected.
 - Printer Baud Rate** - Choose rate at which logging is transferred to the chosen printer.

Connecting an HP 15730A Printer

Description:

An HP 15730A RS-232-C printer can be connected to the HP ProBER 2 printer port for result logging.

HOW TO:

- 1 Connect the HP 15730A printer to HP ProBER 2 printer port using the appropriate cable.
If the printer has a 25 pin connector, use HP Part Number 24542M.
If the printer has a 9 pin connector, use HP Part Number C2932A.
- 2 Choose the printer Baud Rate to match the Baud Rate chosen on the **MENU** **Log/Print** **Setup** display. See, "Logging Results" on page 52.
- 3 Choose Printer Type **HP** on the **MENU** **Log/Print** **Setup** display. See, "Logging Results" on page 52.

NOTE

The HP 15730A printer is for Test and Measurement use only.

Printing a Display

Description:

Any of the HP ProBER 2 displays can be logged to a printer for record keeping or as an illustration in test procedures.

HOW TO:

- 1 Obtain the display required and press **PRINT**.

Using Other Features

Time & Date

Measurement Settings

Beep on Error/Alarm

Display Backlight

Display Contrast

Battery Charging

Self Test

Using Other Features

Setting Time & Date

Description:

When recording results it is useful to have certain events time stamped, for example, Alarms; Error Seconds.

Access Display:

Choose **MENU** **Other** **Time & Date** to obtain the Time and Date display.

HOW TO:

- 1 Move the cursor to **Date** and enter the correct date using **Edit**, **◀** **▶** **▼** and **▲**. Press **ENTER** to action your edits. Press **Cancel** to escape.
- 2 Move the cursor to **Time** and enter the correct time using **Edit**, **◀** **▶** **▼** and **▲**. Press **ENTER** to action your edits. Press **Cancel** to escape.

Storing & Titling Instrument Settings

Description:

Up to 4 sets of user defined instrument settings can be stored in HP ProBER 2 and each set can be given a title for ease of identification.

One preset store is provided which cannot be overwritten, **STORE 0**. This store is used to set the instrument to a known state, the **FACTORY DEFAULT SETTINGS**.

Access Display:

Choose **MENU** **Other** **Inst Settings** to obtain the stored settings display.

HOW TO:

- 1 Choose **Overwrite Protection** **OFF**.
- 2 Choose the memory location in which you wish to store your instrument settings using **▼** and **▲**.
- 3 Choose **Save** to store your instrument settings in the chosen memory location.
Use **Edit**, **INS**, **DEL**, **◀**, **▶**, **▼** and **▲** to enter the title.
Press **ENTER** to action your edits. Press **Cancel** to escape.
- 4 Choose **Overwrite Protection** **ON**.

Recalling Instrument Settings

Description:

Having stored a complete set of measurement settings, you must be able to Recall those settings for use at a later date.

Access Display:



Choose **MENU** **Other** **Inst Settings** to obtain the stored settings display.

HOW TO:

- 1 Overwrite Protection **OFF** or **ON** may be chosen.
- 2 Choose the memory location (0 to 4) from which you wish to recall the instrument settings.
Press **Recall** to recall your instrument settings.

Instrument Reset (Cold Start)

If you cannot control the HP ProBER 2 using the front panel keys perform an Instrument Reset (Cold Start).

- 1 Press and hold down  for longer than 7 seconds.
- 2 When the display blanks (switched off)  can be released.
- 3 To restore power press .
The HP ProBER 2 will return to the Default settings, but any data previously stored in memory will be lost.

Setting Beep on Error/ Alarm

Description:

When the test set display is not in your view it is particularly useful to have an audible indication of Errors and Alarms.

You can set the HP ProBER 2 to beep on errors of a particular type or beep on all error types.

Similarly you can set the HP ProBER 2 to beep on a particular alarm or beep on any alarm.

Access Display:

Choose **MENU** **Other** **Inst Config** to obtain the Beep on Error and Beep on Alarm display.

HOW TO:

- 1 Choose the type of error under **Beep On Error**.
- 2 Choose the type of alarm under **Beep On Alarm**.

Setting Backlight Mode

Description:

Under certain lighting conditions it may be difficult to read the display. The Backlight capability improves the clarity of the display under those conditions.

You can choose to have the Backlight:



- Switch off 1 to 10 minutes after a key press, saving battery power, or
- Switched on continuously.

The Backlight is switched ON and OFF using .

Access Display:

Choose **MENU** **Other** **Inst Config** to obtain the Backlight display.

HOW TO:

- 1 Move the cursor to the **Backlight** field.
If **Timed** is chosen the backlight will remain on after a key is pressed for the user defined period.
Use  and  to set the timed period.

Setting Display Contrast

Description:

The readability of the HP ProBER 2 display can be adjusted using the display contrast control.

NOTE

It is possible to set the contrast such that the display is unreadable, all white or all black.

If you accidentally attain that condition and the power is cycled, you will not be able to set the contrast when power is restored.

The special key sequence



ENTER | **ENTER** | **Softkey 1**

Softkey 1 is provided to set the contrast to a mid position thus allowing the display to be viewed for contrast setting.

Access Display:

Choose **MENU** | **Other** | **Inst Config** to obtain the Contrast display.

HOW TO:

- 1 Use  and  to set the optimum contrast level while viewing the display.

Choosing Local Language Help Messages

Description:

The HELP messages on the HP ProBER 2 are provided in English and some other languages.

Access Display:

Choose **MENU** **Other** **Inst Config** to obtain the local language display.

HOW TO:

- 1 Scroll down to **Language** and choose the language required from the menu.

Charging the Battery

Description:

HP ProBER 2 contains high capacity Nickel Metal Hydride (NMH) rechargeable batteries.

HP ProBER 2 is supplied with a DC charger unit which requires an AC power supply between 100 and 240V, at frequencies between 47 and 63 Hz.

CAUTION

Always use the DC charger unit supplied with HP ProBER 2 for the shortest charge times and best capacity. Performance limitations and damage may occur if other DC charger units are used.

Before use

Before using HP ProBER 2 for the first time it is recommended you:

- Charge the batteries for 24 hours
- Power up HP ProBER 2 and allow it to discharge completely
- Charge the batteries for 12 hours

This ensures that the battery is cycled to give the correct capacity. The capacity will continue to increase for the next few charge/discharge cycles until the nominal value is reached.

NOTE

During the charging cycle some heat may be apparent on the case of HP ProBER 2. This is normal and is due to the fast charge applied to the batteries.

Normal Use

Normally the batteries will be fully charged after 5 hours. It is good practise to allow a 1 hour rest period after charging to allow the battery chemistry to stabilize and obtain the highest battery capacity.

The longest time between charges is obtained in **RX Only** mode with BER measurements running.

The following functions reduce the operating hours:

- Backlight enabled
- **Tx + Rx** operating mode
- Jitter measurements (Option 001 only)
- Pulse Mask measurements (Option 001 only)
- 64 kb/s operation (Option 002 only)

Battery Gauge Indication

The battery gauge indicator can be accessed on the **MENU** **Other** **Battery Life** display and indicates the remaining battery capacity. It monitors the amount of charge input to the batteries and output from the batteries. It allows for self discharge when HP ProBER 2 is switched on and takes account of the ambient temperature.

It learns the maximum battery capacity by measuring the total charge output from fully charged batteries to the fully discharged state and uses this knowledge to display the remaining battery capacity.

NOTE

It is recommended you allow a complete charge/discharge cycle to occur every few months. This ensures the battery gauge accuracy is maintained.

Running Self Test

Description:

Before making measurements, you can run Self Test to ascertain the integrity of the HP ProBER 2. There are three different levels of Self Test:

- **Quick Tests** - Requires a 75Ω loopback. Performs a functional test of the processor and BER circuits and completes in less than a minute.
- **Auto Tests** - Requires a 75Ω loopback. Performs a comprehensive set of self tests **All Tests** and takes a few minutes to complete. The tests included in **All Tests** can be run individually and are intended for use by service technicians in a troubleshooting or repair situation.
- **Manual Tests** - Requires intervention by a service technician and is intended for use by service technicians in a troubleshooting or repair situation.

It is recommended that you run the Quick Test level of self test as a quick confidence test before use.

If necessary you can run Auto Test for more comprehensive testing but this takes a few minutes to complete.

Access Display:

Choose **MENU** **Other** **Selftest** to obtain the Selftest display.

HOW TO:

Run Quick Tests (15 Seconds)

- 1 Choose **Quick Tests**.
- 2 Connect the TRANSMIT 75Ω port to the RECEIVE 75Ω port.
- 3 Press **START/STOP** to run the selftest. After a few seconds an Overall Status PASS or FAIL message will be displayed.

Run Auto Tests (5 minutes)

- 1 Choose **Auto Tests** **All Tests**
- 2 Connect the TRANSMIT 75Ω port to the RECEIVE 75Ω port.
- 3 Press **START/STOP** to run the selftest. While the tests are running the Test Name, Subtest Number and Test Status are updated on the display to show the progress of the test. If a failure is detected the test will halt and Overall Status FAIL will be displayed. At the completion of the test without failure Overall Status PASS will be displayed.

FailNumber	Description	Fail Number	Description
1xxxx	CPU	5xxxx	BER
2xxxx	Real Time Clock	6xxxx	Pulse Mask
3xxxx	Line Level	7xxxx	Jitter
4xxxx	Clock	8xxxx	Delay

Using Other Features

Index

A

Accessing displays 2

Add

errors & alarms 14

frequency offset 15

Alarm

add 14

beep on 61

measurement 28

results 28

type 14

Analysis measurement 30

Autosetup 11

B

Backlight

mode 62

timed 62

Battery

charging 65

gauge indication 66

life 66

Beep

on error/alarm 61

C

Channel associated signalling 17

Channel map 42

Charging battery 65

Clock

IN port 8

source 10

Cold start 60

Connecting to the network 8

Contrast 63, 64

Coupled settings 9

Index

D

Date set 58

DC charger unit 65

Delay measurement 34

Dialling 23

Display

 accessing 2

 contrast 63

 modify data 5

 navigating 3

 print 55

 softkeys 2

DTMF dialling 23

E

Elapsed test time 26

Error

 add 14

 analysis measurement 30

 beep on 61

 event logging 52

 measurement 28

 results 28

 sources 28

F

Frame type 10

Framing bits

 monitor 46

 set 19

Frequency

 offset 15

 offset measurement 36

Frequency measurement 36

G

G.821

Index

- analysis 30
- thresholds 31
- G.826
 - analysis 30
 - thresholds 31
- Gauge indication battery 66
- Generating
 - VF tone 20
- Graph
 - cursor 50
 - display 2
 - resolution 50
- Graph results
 - recall 49
 - save 48
 - text 50
 - view 50
- H**
- Handset 22
- I**
- Instrument settings
 - recall 60
 - store 59
 - title 59
- Interval results 53
- J**
- Jitter
 - filters 40
 - measurement 40
- L**
- Language choice 64
- Line
 - impedance 10
 - rate 10
- Live word pattern 10

Index

Local language help 64

Log/Print display 2

Logging

alarm seconds 53

cumulative results 53

display 55

error counts 53

error event 52

errored seconds 53

filters 53

frequency measurement 53

G.821 results 53

G.826 results 53

interval 53

interval results 53

mode 53

signal level 53

test period 52

M

Manual test timing 27

Measuring

delay 34

error analysis 30

errors & alarms 28

frequency 36

frequency offset 36

jitter 40

pulse mask 37

signal level 39

VF tone 42

Modifying display data 5

Monitor

framing bits 46

signalling bits 44

spare bits 45

termination 8

Index

- timeslots 43
- More softkey 4
- N**
- Navigating displays 3
- O**
- Other display 2
- Overwrite thru mode 9
- P**
- Path allocation 30
- Print
 - alarm seconds 53
 - cumulative results 53
 - display 55
 - error counts 53
 - error event 52
 - errored seconds 53
 - frequency 53
 - G.821 results 53
 - G.826 results 53
 - interval results 53
 - signal level 53
- Printer
 - baud rate 54
 - connecting 54
 - HP 15730A 54
- PUAS
 - threshold 31
- Pulse mask measurement 37
- R**
- Recall
 - graph results 49
 - instrument settings 60
- Receive
 - Interface 9
 - interface termination 8

Index

only 9

Reset instrument 60

Results

display 2

graph 50

logging 52

S

Save graph results 48

Self test 68

Set

backlight 62

display contrast 63

error/alarm beep 61

framing bits 19

signalling bits 17

spare bits 18

time & date 57, 58

Settings coupled 9

Signal level measurement 39

Signal quality display 2

Signalling bits

monitor 44

set 17

Spare bits

monitor 45

set 18

Store instrument settings 59

Synchronization status message. 18

T

Telephone handset 22

Test period

logging 52

Test setup display 2

Test timing 26

Index

- Text results 50
- Threshold
 - PUAS 31
- Thresholds
 - G.821 31
 - G.826 31
- Thru mode 9
- Time set 58
- Timeslots 10
- Title instrument settings 59
- Total results 53
- Transparent thru mode 9
- Trouble scan 32
- TX/RX setup display 2
- V**
- VF tone
 - generating 20
 - measurement 42
- View
 - alarm results 28
 - channel map 42
 - delay result 34
 - error results 28
 - frequency results 36
 - G.821 analysis results 30
 - G.826 analysis results 30
 - graph results 50
 - jitter results 40
 - pulse mask results 37
 - signal level result 39
 - time & date 58
 - trouble scan 32
- W**
- Word pattern 10

Index

Hewlett-Packard Sales and Service Offices

If you need technical assistance with a Hewlett-Packard test and measurement product or application please contact the Hewlett-Packard office or distributor in your country.

The list of Hewlett-Packard Sales and Service Offices listed below may not be up to date. An up to date and complete list can be found on the World Wide Web at: <http://www.tmo.hp.com/tmo/contacts/English/callcenters.html>

Asia Pacific:

Hong Kong:

Tel: (852) 2599 7889

India:

Tel: (91-11) 682-6000

Japan:

Hewlett-Packard Japan Ltd.
Measurement Assistance Center
9-1, Takakura-Cho, Hachioji-Shi,
Tokyo 192-8510, Japan
Tel: (81) 426-56-7832
Fax: (81) 426-56-7840

Korea:

Tel: (82-2) 769 0800

Malaysia:

Tel: (60-3) 291 0213

Philippines:

Tel: (63-2) 894 1451

Hewlett-Packard Sales and Service Offices

People's Republic of China:

Tel: (86-10) 6505 0149

Singapore:

Tel: (1800) 292 8100

Taiwan:

Tel: (886-3) 492 9666

Thailand:

Tel: (66-2) 661 3900

For countries in Asia Pacific not listed, contact:

Hewlett-Packard Asia Pacific Ltd
17-21/F Shell Tower, Times Square,
1 Matheson Street
Causeway Bay
Hong Kong
Tel: (852) 2599 7777
Fax: (852) 2506 9285

Australia/New Zealand:

Hewlett-Packard Australia Ltd.
31-41 Joseph Street
Blackburn, Victoria 3130
Australia
Tel: 1 800 629 485

Canada:

Hewlett-Packard Canada Ltd.
5150 Spectrum Way
Mississauga, Ontario
L4W 5G1
Tel: (905) 206 4725

Hewlett-Packard Sales and Service Offices

Europe, Africa and Middle East:

Austria:

Tel: (0)1 25000-0

Belgium and Luxembourg:

Tel: (02) 778 3417

Baltic Countries:

Tel: (358) 08872 2100

Czech Republic:

Tel: 420-2-4743111

Denmark:

Tel: 45 99 10 00

Finland:

Tel: (90) 88 721

France:

Tel: (0)1 69.82.60.60

Germany:

Tel: (0180) 532 62-33

Greece:

Tel: 30-1-7264045

Hungary:

Tel: 36-1-4618219

Ireland:

Tel: (01) 284 4633

Israel:

Tel: 972-3-5380333

Hewlett-Packard Sales and Service Offices

Italy:

Tel: 02 - 92 122 241

Netherlands:

Tel: (020) 547 6669

Norway:

Tel: (22) 73 57 50

Poland:

Tel: 48-22-6087700

Portugal:

Tel: (11) 482 85 00

Russia:

Tel: (7/095) 928 6885

Fax: (7/095) 916 9844

South Africa:

Tel: 27-22-8061000

Spain:

Tel: (34) 1 631 1323

Sweden:

Tel: (08) 444 22 77

Switzerland:

Tel: (01) 735 7111

Turkey:

Tel: 90-212-2245925

United Kingdom:

Tel: (01344) 366 666

Hewlett-Packard Sales and Service Offices

For countries in Europe/Middle East and Africa not listed, contact:

Hewlett-Packard
International Sales Europe
Geneva, Switzerland
Tel: +41-22-780-4111
Fax: +41-22-780-4770

Latin America:

Hewlett-Packard
Latin American Region Headquarters
5200 Blue Lagoon Drive
9th Floor
Miami, Florida 33126
U.S.A.
Tel: (305) 267-4245
Tel: (305) 267-4220
Fax: (305) 267-4288

United States:

Hewlett-Packard Company
Test and Measurement Organization
5301 Stevens Creek Blvd.
Bldg. 51L-SC
Santa Clara, CA 95052-8059
Tel: 1 800 452 4844

Hewlett-Packard Sales and Service Offices



About This Edition

This is the First edition of the E7580-90000 manual. It documents the product as of 12/98. Edition dates are as follows:

1st Edition, 12/98

© Copyright Hewlett-Packard Company 1998. All rights reserved. Reproduction, adaption, or translation without prior written permission is prohibited, except as allowed under the copyright laws.

In This Book

Printed in U.K. 12/98
E7580-90000

